

Lever handles

Technopolymer

MATERIAL

Glass-fibre reinforced polyamide based (PA) technopolymer, black colour, matte finish.

FRONT PLATE

Matte anodised aluminium.

STANDARD EXECUTIONS

- **MF-B:** brass boss, threaded blind hole.
- **MF-N:**
 - cylindrical blind hole, brass reinforcement and transversal semi-machined hole for pinning to shaft.
 - square blind hole, brass reinforcement with transversal set screw UNI 5929-85 (grub screws with hexagon socket and cup end).
- **MF-p:** zinc-plated steel threaded stud, chamfered flat end UNI 947 : ISO 4753 (see Technical Data on page A11).



ELESA Original design stuttgart

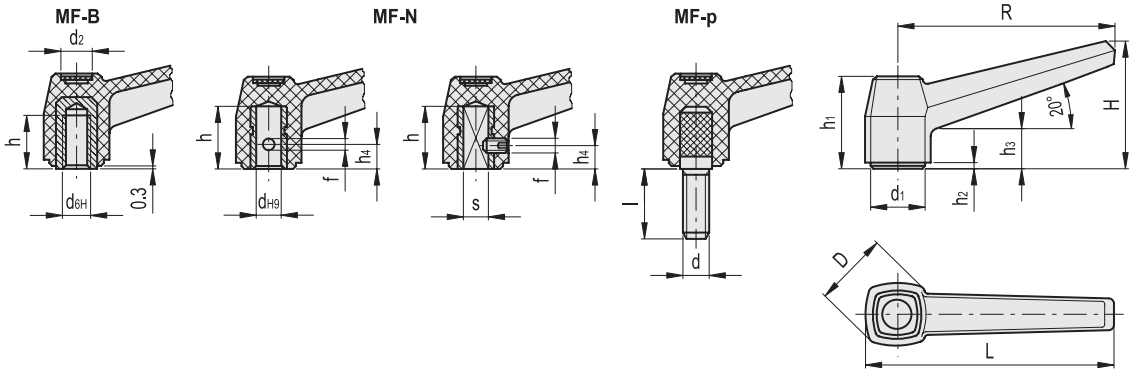

MF-B

Code	Description	R	d6H	L	D	H	h	h1	h2	h3	d1	d2	⚖
39041	MF.40 B-M5	42	M5	50	18	27	10	22	1.8	9	11.5	9	14
39001	MF.40 B-M6	42	M6	50	18	27	12	22	1.8	9	11.5	9	13
39111	MF.63 B-M8	63	M8	73	23	37	13	27	2	11	14.5	9	23
39211	MF.80 B-M10	80	M10	92	28	47	17	34	2.2	14	18.5	11	39
39311	MF.100 B-M12	100	M12	115	35	57	20	40	2.4	16	23.5	13	70

MF-N

Code	Description	R	dH9	sH9	L	D	H	h	h1	h2	h3	h4	d1	d2	f	⚖
39011	MF.40 N-5x5	42	-	5	50	18	27	15	22	1.8	9	7	11.5	9	M4	7
39021	MF.40 N-6	42	6	-	50	18	27	15	22	1.8	9	7	11.5	9	3	7
39121	MF.63 N-6x6	63	-	6	73	23	37	20	27	2	11	8	14.5	9	M4	14
39131	MF.63 N-8	63	8	-	73	23	37	20	27	2	11	8	14.5	9	4	14
39221	MF.80 N-8x8	80	-	8	92	28	47	25	34	2.2	14	9	18.5	11	M5	27
39231	MF.80 N-10	80	10	-	92	28	47	25	34	2.2	14	9	18.5	11	4	27
39321	MF.100 N-10x10	100	-	10	115	35	57	30	40	2.4	16	10	23.5	13	M5	50
39331	MF.100 N-12	100	12	-	115	35	57	30	40	2.4	16	10	23.5	13	5	50

MF-p

Code	Description	R	d6g	L	D	H	h1	h2	h3	d1	d2	l	⚖
39031	MF.40 p-M6x16	42	M6	50	18	27	22	1.8	9	11.5	9	16	12
39141	MF.63 p-M8x25	63	M8	73	23	37	27	2	11	14.5	9	25	28
39241	MF.80 p-M10x30	80	M10	92	28	47	34	2.2	14	18.5	11	30	51
39341	MF.100 p-M12x50	100	M12	115	35	57	40	2.4	16	23.5	13	50	104